

PRESSURE PLATE
(MOVABLE)

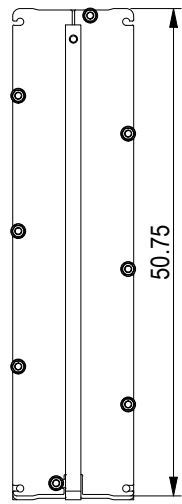

Space between pressure plate and supporting column should be kept free from fixed installations!

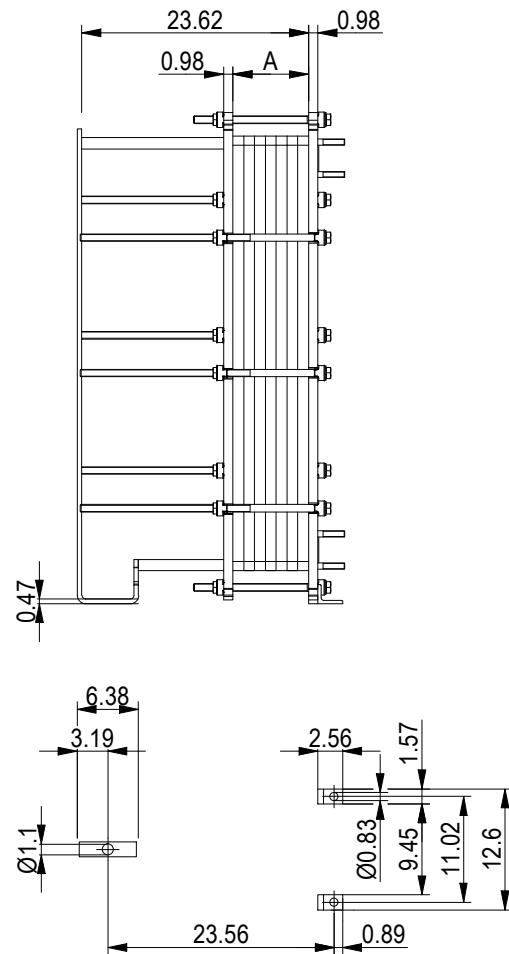

FRAME PLATE

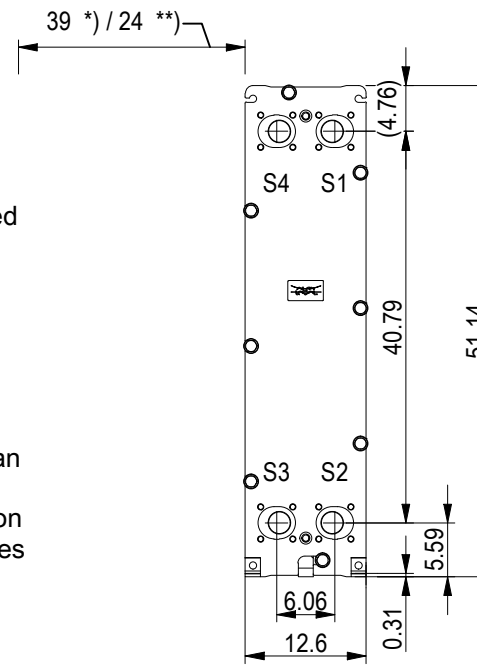

*) Recommended free space for opening and closing to be applied on both sides

**) Free space can be reduced to this distance on one of the sides

All dimensions in inches

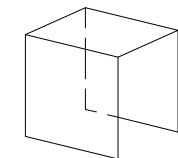
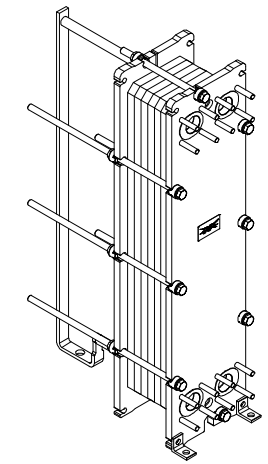

PROTECTION SHEET

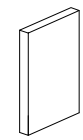

PRESSURE PLATE

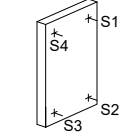

FRAME PLATE

ASME B16.5 Class 150 NPS 2
S1, S2, S3, S4

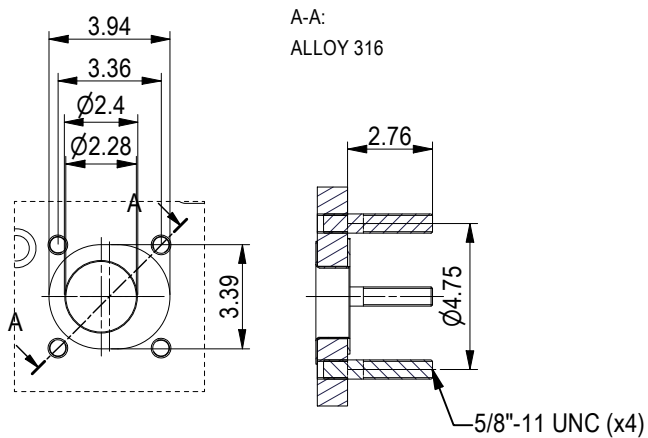

NO. OF UNITS 1

null GPM
null GPM

APPROX. OUTER DIMENSIONS	
LENGTH	28.7 in
WIDTH	13.0 in
HEIGHT	51.6 in
APPROX. WEIGHTS	
NET WEIGHT, EMPTY	573 lb
WEIGHT FULL OF WATER	637 lb
PLATE MATERIAL	ALLOY 316
PLATE THICKNESS	0.5 mm
GASKET	NBRP Clip-on

CHANNEL ARRANGEMENT 1*34 MH / 1*35 ML



www.alfalaval.com

DRAWING
GASKETED PLATE HEAT EXCHANGER

TL6-BFG

ASME
Code Section VIII Div.1

MAWP 150 psi at 150.1 °F
MDMT 32.0 °F at 150 psi
Designed and constructed in accordance with the 2019 ASME Code.

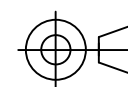

8240152999
TL6-BFG, 70 plates

Do not use this drawing for foundation bolting or piping layout

DATE 5/2/22
REVISION 0